

PROSISTEL

Antenna Rotator

User's manual

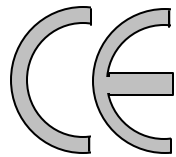

**Array Solutions-RME Filters, Inc.
350 Gloria Rd.
Sunnyvale, Texas ,USA
75182**

**Phone: 972-203-2008
Fax: 972-203-8811**

E-mail: wx0b@arraysolutions.com

Web Site: www.arraysolutions.com

Warning

This manual must be read carefully before proceeding with wiring and installation

Warranty

- 1) The rotator with the control box, hereafter called "rotator" or "product", is warranted for 2 years from date of purchase.
- 2) The warranty covers replacement or repair of the defective component.
- 3) This warranty does not apply to product which have been subjected to misuse, negligence, incorrect wiring performed by the user, improper installation or non-compliance to instructions furnished by Array Solutions Inc., damage to product which has been repaired or altered without authorization or to injury resulting from careless maintenance. The warranty does not cover damage due to transportation.
- 4) The warranty does not cover costs and risk relating to the shipping of the rotator for repair.
- 5) Array Solutions, Inc. is not responsible for personal injury or property damage resulting from improper or careless use of the rotator.
- 6) This warranty is not cover damage to people or things due to misuse, improper or careless installation, or misunderstanding of instructions furnished by Array Solutions, Inc.
- 7) Array Solutions, Inc. reserves the right to implement improvements and changes without prior notification.

Model: PST _____

S/N: _____

Date of purchase: _____

Introduction

This manual contains installation, use and maintenance information for the models PST 51, 61, and 71 antenna rotators.

Table of Contents

Section 1:	Description
Section 2:	Installation and Wiring
Section 3:	Principles of Operation
Section 4:	Specifications
Section 5:	Special Functions
Section 6:	Mounting Hole Pattern
Section 7:	Tower Mounting Information
Section 8:	Schematic - Model A Control Box
Appendix 1:	Model B Control Box
Appendix 2:	Model C Control Box
Appendix 3:	Connector Information

Section 1

Description

1.1 General

This manual provides information for installation on a mounting plate inside a tower or a rotator cage with a thrust bearing. The rotator consists of a motor unit and a control box.

1.2 Unpacking and Inspection

Be sure to check the rotator and control box for damage, especially if there is damage to the shipping carton.

1.3 Control Box

The following functions are located on the front panel of the control box (Fig. 1): power switch, rotation direction switch and the digital display that indicates the antenna position in degrees. **(See appendix 1 for Model B control box and appendix 2 for Model C control box)**

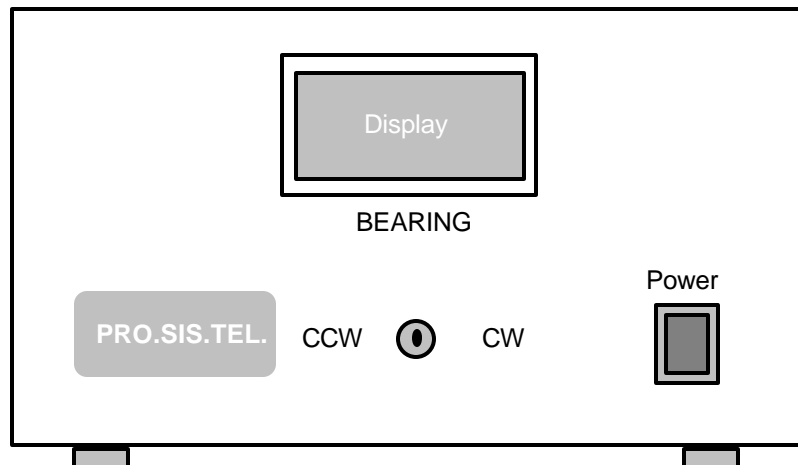

Fig. 1

On the rear of the control box the following is located (Fig. 2): AC line power input socket, fuse holder, rotator control cable socket and DB9S connector for remote control (i.e. computer interface or footswitch).

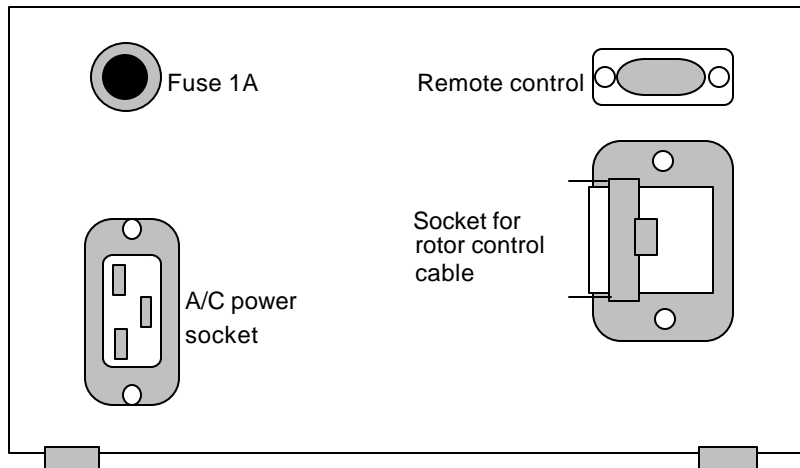
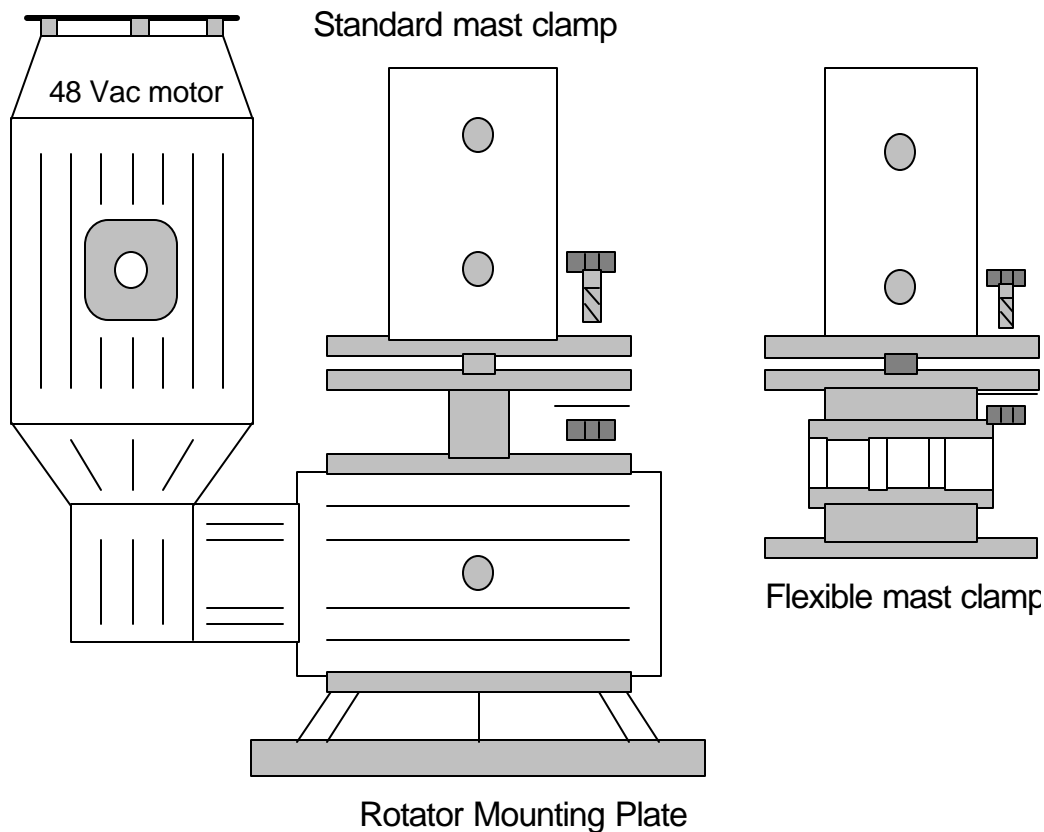
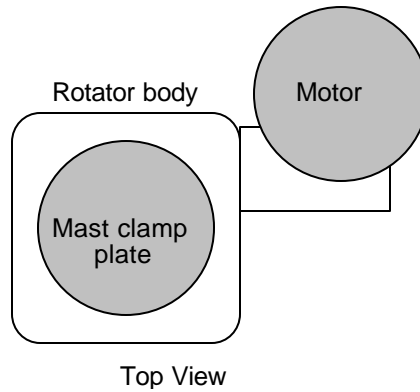

Fig. 2

1.4 The Rotator

The motor is located on the side of a double worm geared drive in vertical position and covered with a plate to prevent snow and ice from entering the motor fan. The main gear box is terminated on a flat plate and provides the rotation motion to the antenna via mast clamp. A standard mast clamp is provided with the rotator. (There are several optional mast clamp assemblies available. Contact Array Solutions for more information) A weather proof housing is located on the side of the motor. A six terminal connection block is located inside this housing. Connections are provide for motor power, bearing indication potentiometer, and ground. The potentiometer is located in the main gear box.





1.4.1 Accessories

Rotator is supplied with following accessories: AC power cable, plug for rotator control cable, standard mast clamp, stainless steel hardware and users manual.

Section 2 Installation and Wiring

2.1 Control Cable Preparation & Connection

Before installing rotator inside tower, you need to prepare the rotator control cable and test rotator for proper operation on the ground. The rotator requires 7 wires. Three wires for motor power, 3 wires for the position potentiometer and 1 wire for ground. The required wire size is a function of cable length. Improper wire size will result in reduced voltage to the motor and limit torque. Minimum wire size based on maximum cable length is indicated in the chart below. The three heavier wires are used to power the motor. You can parallel conductors (if the cable has more than 7 wires) to achieve the minimum conductor size.

Model	PST 51	PST 61	PST 71
150 feet	Three #18 and four #22	Three #18 and four #22	Three #16 and four #22
150 to 300 feet	Three #16 and four #22	Three #16 and four #22	Three #14 and four #22

An 8 pin connector (only 7 of the 8 pins are used) is used to connect the rotator cable to the control box. The cable wires must be soldered to the connector pins. Connections to the motor terminal block made via ring terminals. Make sure that you use a proper crimping tool.

Warning: The control cable connector pins snap into the connector body and cannot be removed, once inserted. Make sure that you have a good solder connection to the pin and that the proper wire is inserted into the correct pin location. The pin numbers are stamped on the cable end of the connector body. Do not operate the rotator until you have ALL 7 connections made between the control box and rotator.

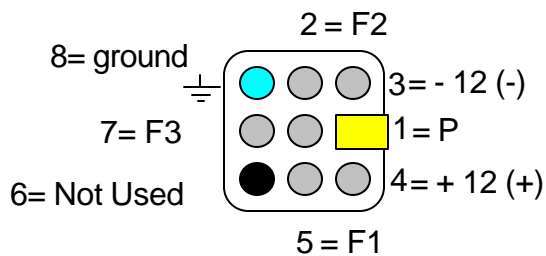
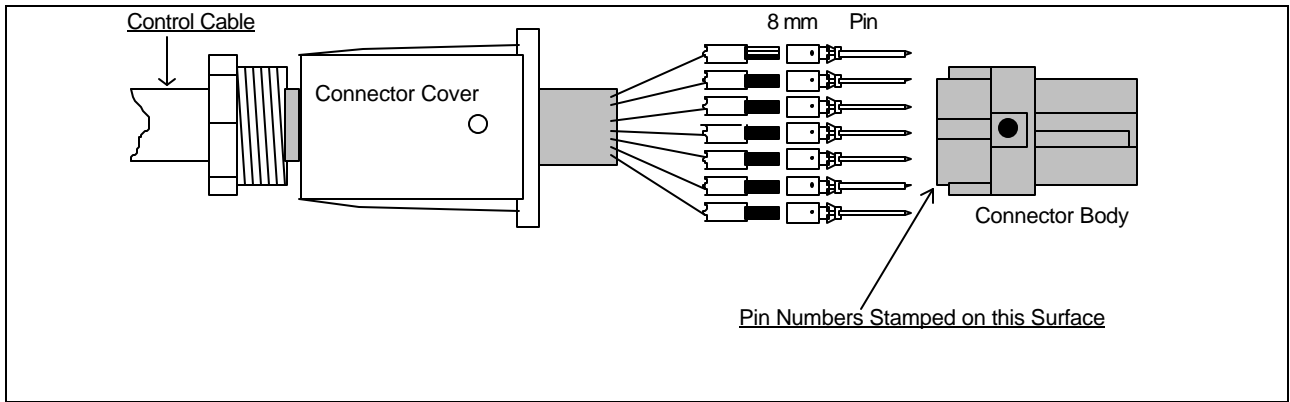

Control cable connector body

!! viewed from cable end !!

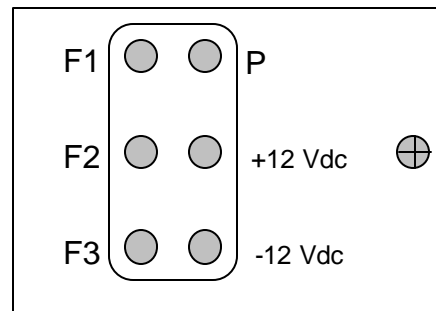

View looking at the terminal block located on the motor

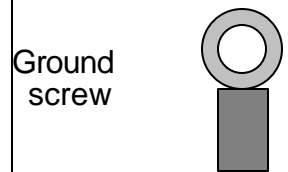

Ring Terminal

Control Box	Motor	Function	Wire Color
Pin #1	P	Pot Wiper	
Pin #2	F2	Motor CCW	
Pin #3	-12	-12 Vdc to pot	
Pin #4	+12	+12 Vdc to pot	
Pin #5	F1	Motor Common	
Pin #6 (No Connection)	No Connection	No Connection	
Pin #7	F3	Motor CW	
Pin #8	Ground	Ground	

Warning: Improper wiring can result in damage of the motor and/or control box. Double check your wiring and connections!!!!

2.2 Inspection

Carefully check the rotator and control box cable connections before turning on the power for the first time.

2.3 Pre-installation check

Control box is preset for 117 VAC (USA). Contact Array Solutions if you require information for product use with 220 VAC. **(See Appendix 1 if you have a Model B control box and appendix 2 for model C control box)** Connect the power cable to a suitable 117 VAC outlet and switch power on. The display will show 000°. Switch power off and insert the control cable connector into the socket on the rear of the control box. Switch power on and if all connections are correct, display will show about 000°. If the bearing display indicates a value much different, switch the power off and check the control cable connections. Push the direction lever in CW direction and rotator will turn to the right or clockwise rotation. The display value will follow the rotator rotation. Continue turning CW until the rotator hits the electronic clockwise stop. The motor rotation should stop and the display will show about 400°. You should be able to notice a difference in the sound of the motor when it hits the electronic stop. Switch direction lever to CCW rotation and rotator will turn back to the left, counter clockwise rotation. Continue turning in the CCW direction until you hit the CCW electronic stop. The display should indicate about -40°. Proceed back in the CW direction until the display reads 000° and shut the power off.

2.4 Troubleshooting

A) Motor does not respond

- 1) Check the motor and connector wiring.
- 2) Check the fuse. If it has failed, replace it and turn the power on. If it fails again, remove the control cable connector from the back of the control box and turn the power. If the control box display is lit, the problem is probably in the cable wiring.

B) Motor turns in the opposite direction

- 1) Check the connections (F1, F2 and F3) on the motor terminal board.
- 2) Check the control cable pin wiring and pin location in the connector housing.

C) When motor was running in reverse of the desired direction (See B above), the electronic stop was activated and now the motor will not respond

- 1) Switch off the control box and disconnect terminal P on the motor terminal block. Connect a volt meter between the P wire of the control cable and ground. Switch on the control box and run the motor until the voltage reads 0.1 Vdc (100 mv). Reconnect wire P on the motor terminal block.

D) Motor turns correctly but the displayed direction is reversed

- 1) Pins 3 (-12 Vdc) and 4 (+12 Vdc) may be reversed.
- 2) Plus (+) and minus (-) may be reversed on the motor terminal block.

E) Rotator turns, but the display does not respond accordingly

- 1) Check connection between pin1 on the connector and P on the motor terminal block.
- 2) Check connection between pins 3 and 4 on the connector and -12/+12 Vdc on the motor terminal block.
- 3) Remove the cable connector from the back of the control box. Turn the control box on and verify that there is +12 Vdc on pin 4 to ground and -12 Vdc from pin 3 to ground.
- 4) Check the rotator potentiometer circuit. Disconnect the control cable plug from its socket and check the resistance between pins 3 and 4. The resistance should be about 10 K ohms. Check resistance between pins 1 and 3 and pins 1 and 4. The value should be between 4 and 6 K ohms. The sum should be about 10 K ohms.

2.5 Control Box Adjustment

All trim pots are set at the factory. A long control cable length may cause the discrepancy in the display reading verses the actual antenna bearing at 0° and 360°. This may be corrected by making an adjustment to trimmer 1 (see Fig. 3, turn limit circuit). Turn the rotator until the display reads 000°. Make reference marks on the rotator plate and rotator body. Turn the rotator all the way around until the marks align. If the bearing display does not read 360°, slowly turn trimmer 1 so the display indicates 360°. The electronic turn limits may be adjusted by turning trimmer 2 for the CCW limit and trimmer 3 for CW limit. Due to the component tolerances, the indicated voltages may be slightly different. **(See Appendix 1 if you have a Model B control box and appendix 2 for Model C control box)**

Turn limit settings are as follows: trimmer 3 (CW limit) Pin 3 of IC U3a = - 0.123 Vdc at -040°
 trimmer 2 (CCW limit) Pin 6 of IC U3b = + 1.219 v on + 400°
 (use digital voltmeter on 2V dc scale)

Turn limits may be set without digital voltmeter but do this carefully. Turn rotator to 000°. This is the starting reference. Simultaneously turn the rotator in the CCW direction while slowly turning trimmer 3 in the clockwise direction. The rotator should stop. Note the display reading and make final adjustment to trimmer 3 until the motor stops at about -40°. Follow the same procedure to set the CW limit by adjusting trimmer 2 and setting the rotation limit to about 400°.

2.6 Installation.

Before drilling holes in the tower mounting plate, make sure that there is no mechanical interference between the rotator body and the tower. Put the antenna mast inside the mast clamp and lock it in the center. The center axes line must be within 5°. Mark and drill the holes in rotator mounting plate. Use the four bolts, washers, and self-locking nuts to secure the rotator to the mounting plate. Before tightening the bolts, insert the antenna mast in mast clamp. Turn rotator and observe the position of the rotator and mounting plate. Adjust the rotator position so that the center axis line is within 5°. Tighten the bolts.

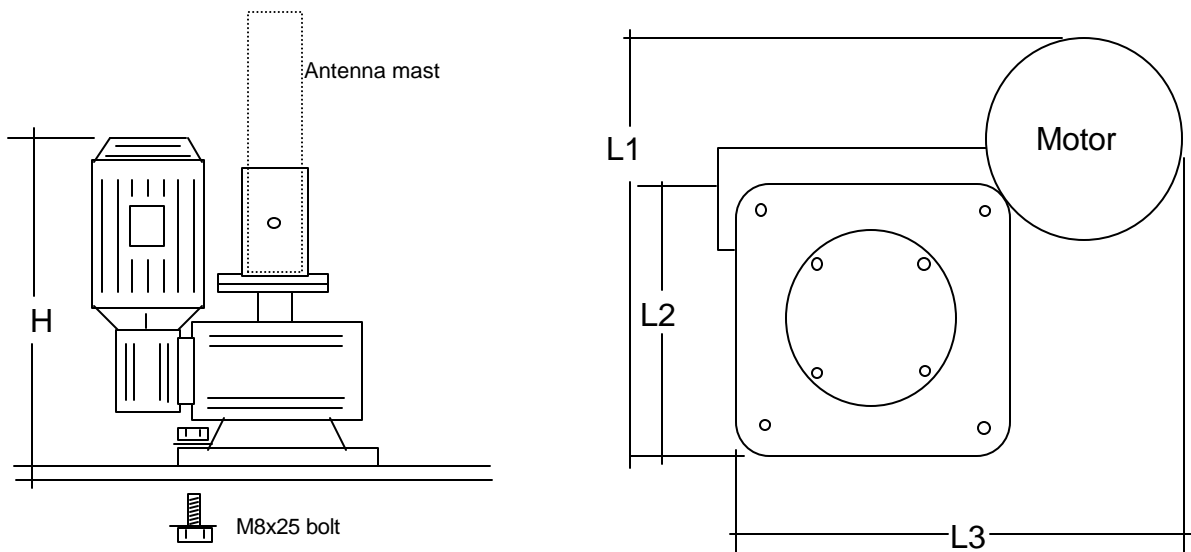

Dimensions:	PST 51	PST 61	PST 71
H = cm - inches	31 - 12	33 - 13	36 - 14
L1 = cm - inches	21 - 8	33 - 13	34 - 13 1/2
L2 = cm - inches	16 - 6	18 - 8	22 - 9
L3 = cm - inches	25 - 10	27 - 11	34 - 13 1/2

Note: Dimensions may be changed without notice.

2.7 Antenna Direction Alignment

Turn the antenna mast until the antenna points in the same direction as indicated on the control box display. Tighten the bolts on the rotator mast clamp. You may choose to drill a hole through the antenna mast and use the bolt provided. Make sure that there is a sufficient loop in the antenna feed line. Remember that Big Boy rotators have a rotation range of 440°.

2.8 Rotator Maintenance

Double worm geared motor is lubricated for life. No maintenance is required. If you live in an industrial zone or near salt water, you may experience some corrosion with time. Rotators are coated with anticorrosive paint at the factory. If paint maintenance is necessary, use ordinary anticorrosive paint for ferrous metal.

Section 3

Principles of Operation

3.1 Rotator

Rotator assembly is motor driven double worm gear drive. The 48 Vac motor is high torque. This technique is normally used on heavy industrial machinery. The high gear reduction provides for high torque using a low horse power motor. The double worm gear drive has an inherent self –breaking action.

3.2 Electrical Configuration

Fig. 3. shows the layout of the main PC board. (See Appendix 1 if you have a Model B control box and appendix 2 for Model C control box)

3.2.1 Indicator circuit

A four digit 7 segment display is used as bearing indicator. This circuitry is power a separate DC power supply.

3.2.2 Turn limiting circuit.

The turn limiting circuit is powered with +12 Vdc and -12 Vdc. These voltages are applied to the potentiometer located in the bottom of the motor unit. The voltage produced at the wiper of the potentiometer “P” is supplied to the comparator (IC U3). Trimmers 2 and 3 set the CW and CCW turn limits.

3.2.3 Motor power control

Motor voltage is switched using optically coupled triacs for each AC line. The motor capacitors are located on the main printed circuit board.

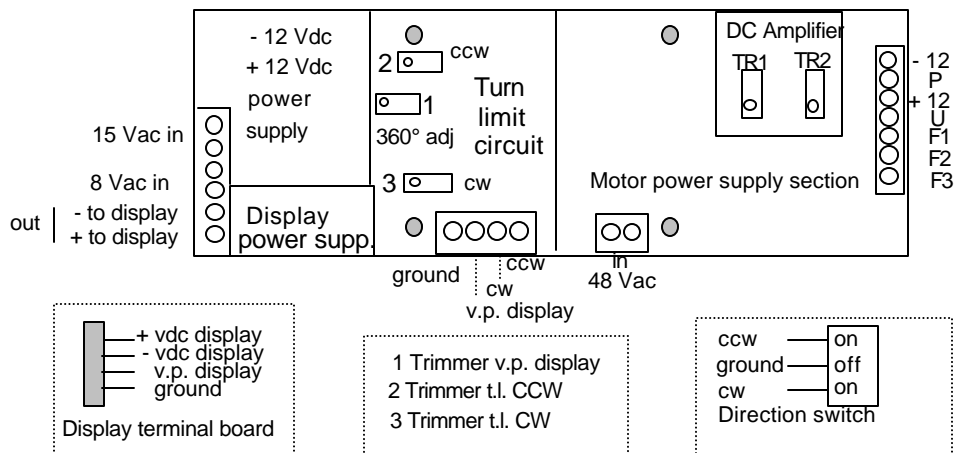

Fig. 3. Connections on Printed Circuit Board.

Section 4

Specifications

4.1 Double Worm Gear Motor

The double worm geared motor has a waterproof aluminum case.
Built in accordance with CEE 89/392/CEE standard.

4.2 Motor

High-starting-torque 48 VAC capacitance motor in aluminum case.
Built in accordance with CE and UL/USA standard.

4.3 Anticorrosive Treatment

Rotator is painted with high resistance paint.

4.4 Control Box

Case in hot painted steel.

Display tolerance: 1° after 5 minutes power on

Dimensions: H = 5 in W = 8 in L = 8.25 in

Weight: 16 lbs

Power supply: 117/220 Vac 50/60 Hz, 300 W

Built in accordance with CE standard.

Specification Table

Model	PST 51	PST 61	PST 71
Wind load area (sq ft)	23	36	81
Braking torque (in lbs)	10,800	26,100	45,000
Rotating torque (in lbs)	6,470	16,426	26,800
Starting torque (in lbs)	6,350	10,600	26,800
Vertical load (lbs)	1,841	2,585	3,190
Motor voltage (Vac)	48	48	48
Motor power (watts)	110	110	190
Rotation range	440°	440°	440°
Rotation time for 360°	70 sec.	100 sec.	130 sec.
Control cable (# of conductors)	7	7	7
Weight (motor unit) (lbs)	31	42	55
Control box power (Vac)	117 or 220	117 or 220	117or 220

Note: Specifications subject to change without notice.

Section 5

Special Functions

5.1 Remote control.

The DB9S connector is on the rear of the control box and allows for remote control of the rotator via a computer or a foot switch.

5.2 Computer Control

Rotator remote control had been tested and works well with the follows computer interfaces: Sartek1, ARS, and Trak.

The output voltage is available on pin 7 of the DB9 connector. This voltage is adjustable between 2 and 10 Vdc using trimmer TR2. Be sure to check the voltage input requirements and limits of your computer interface before hooking it up. The output voltage is set at the factory for 5 Vdc at a rotator display indication of 360°.

5.3 DC Amplifier

An adjustable DC amplifier is used generate the DC output to the computer interface. This voltage is proportional to the bearing indication. (See Fig. 3)

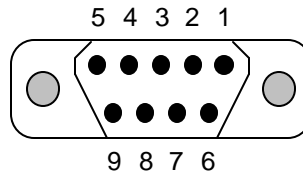
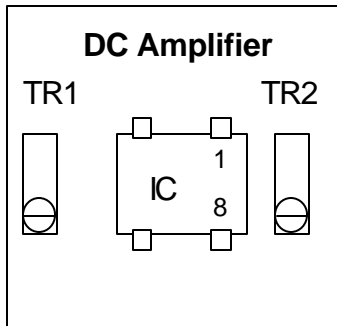

- 1- 5 = not used.
- 6 = ground
- 7 = antenna direction output voltage "U"
- 8 = CW
- 9 = CCW

Turn rotator to 000°. Connect a digital voltmeter between pin 7 of the DB9 connector and ground. If the voltage is not close to 0 Vdc, adjust TR1 using the 200 mv scale on the meter. Turn the rotator to 360° and adjust TR2 to the voltage required by your computer interface. Remember that this voltage will increase as you go past 360° and hit the electronic limit. If your computer interface will not handle this higher voltage, you may have to readjust the CCW limit to 000° to prevent damage to the interface.

Section 6

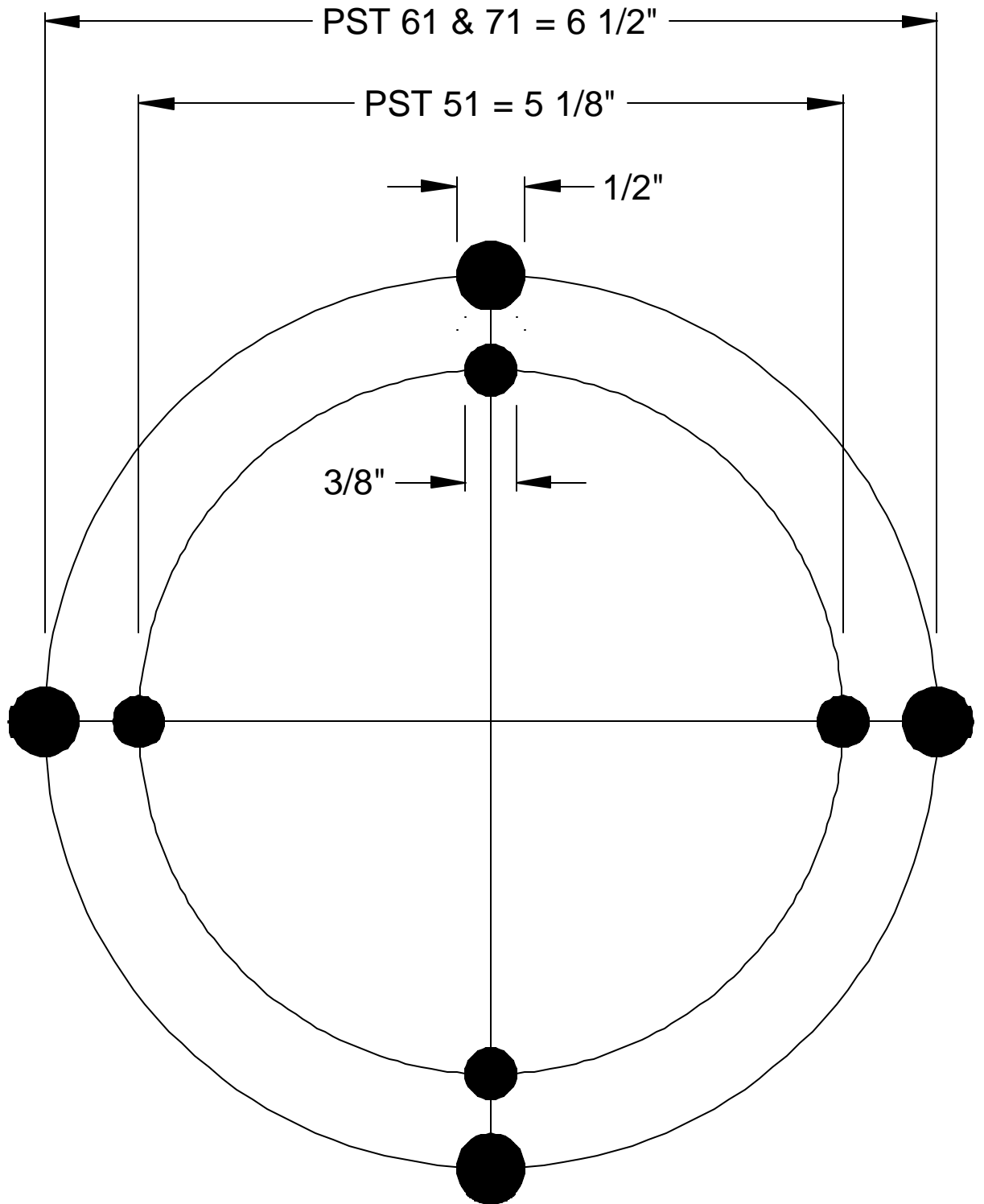

PST Series Mounting Pattern

Section 7 Tower Mounting Information

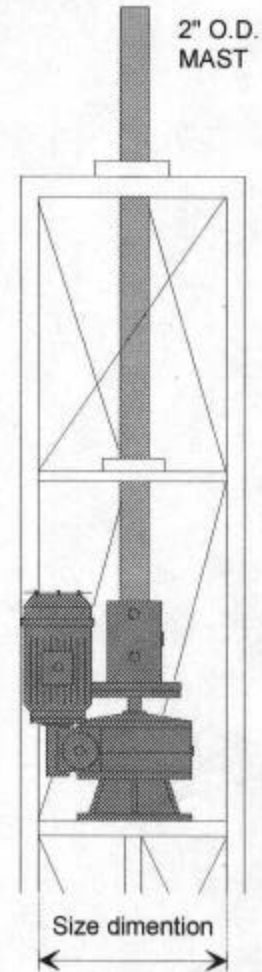
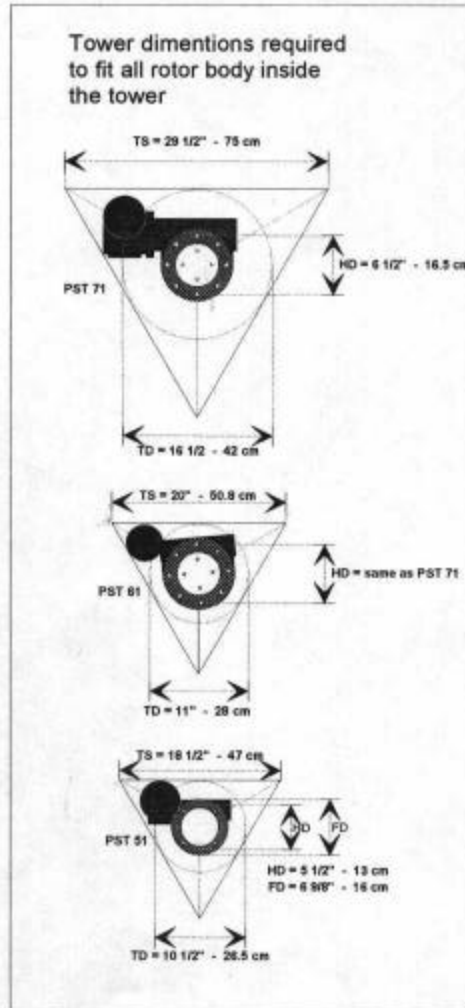

Tower size dimensions required to fit rotor body inside the towers were motor body protude out the tower

PST 51 = 10 inch
 PST 61 = 12 inch
 PST 71 = 14 inch

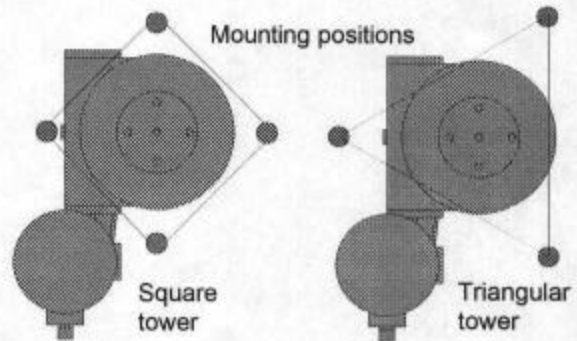

Section 8 Schematic - Model A Control Box

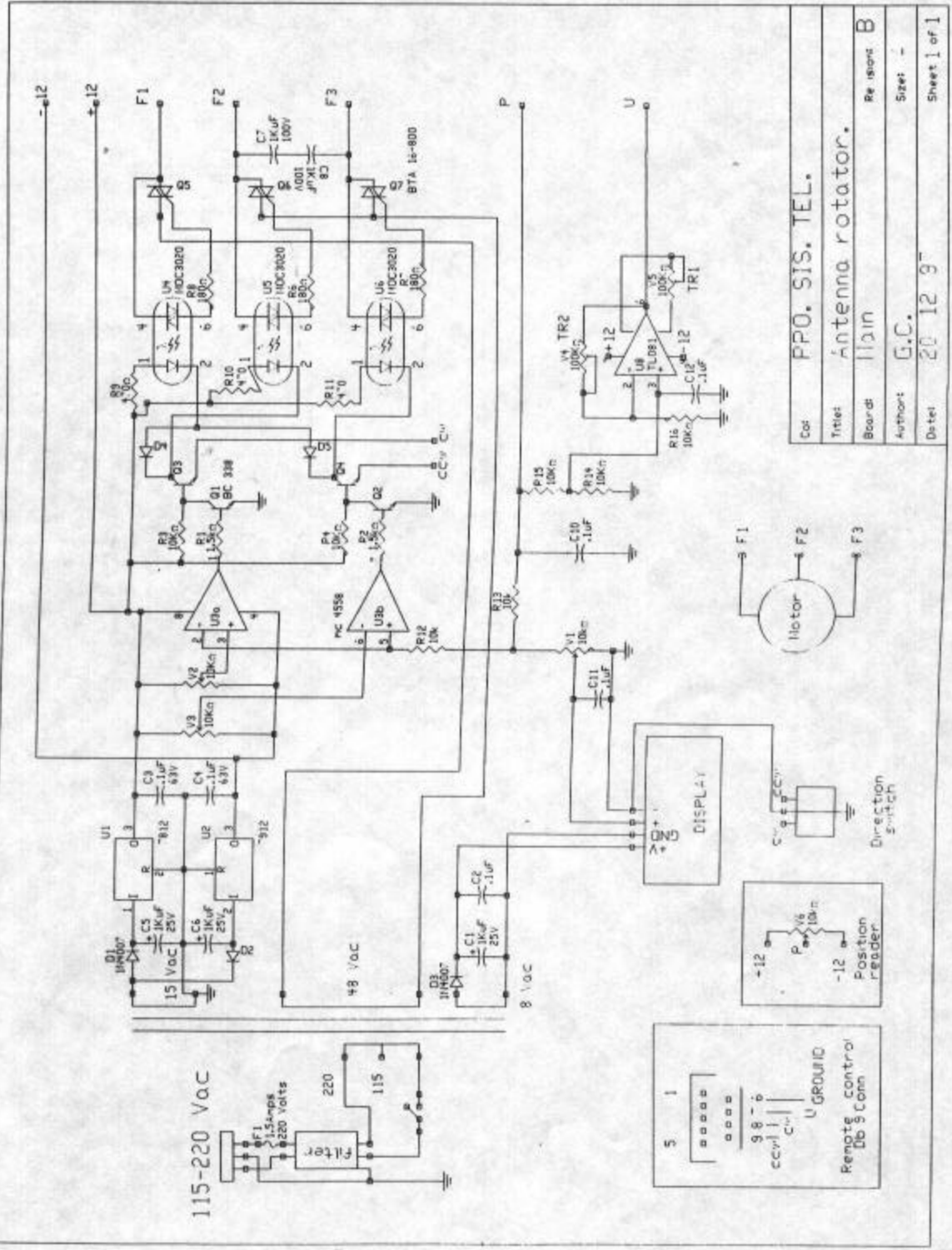

Cat:	PPO. SIS. TEL.		
Title:	Antenna rotator.		
Board:	1131M		
Author:	G.C.		
Date:	20 12 9		
Revison:	B		
Size:	-		
Sheet:	1 of 1		

Appendix 1 Model B Control Box

Features:

- Paddle Switch
- South Stop
- Preset (3 degree Increment)
- Soft Stop
- + 70° and – 70° Overlap
- Reverse Delay
- Other Features Same as Model A Control Box

Warning: The control box is complex. Make sure that you read and understand this section. Test the rotator on the ground before you install it in the tower.

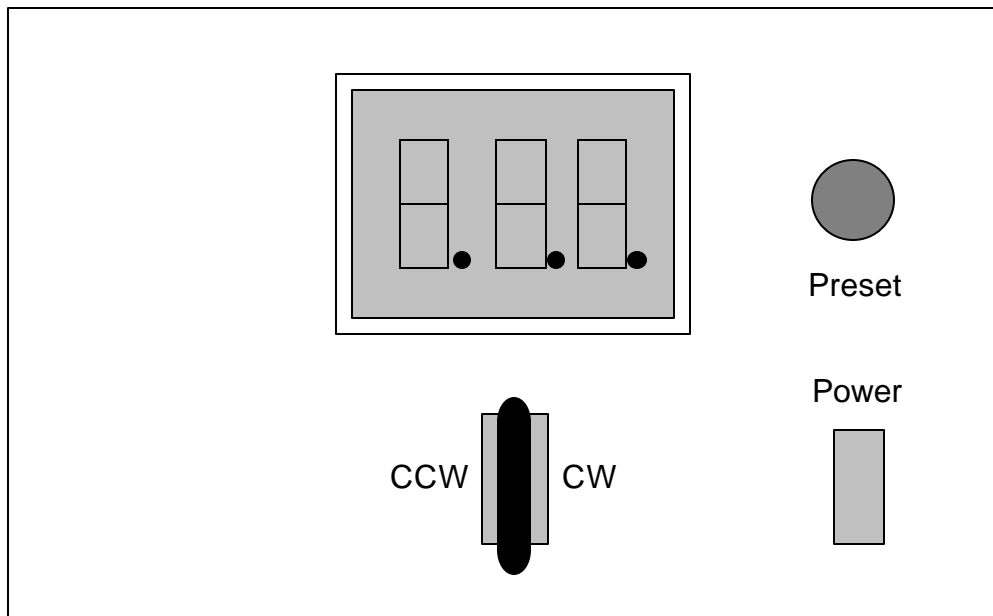

Model B Control Box Front Panel

1 Indicator Assembly

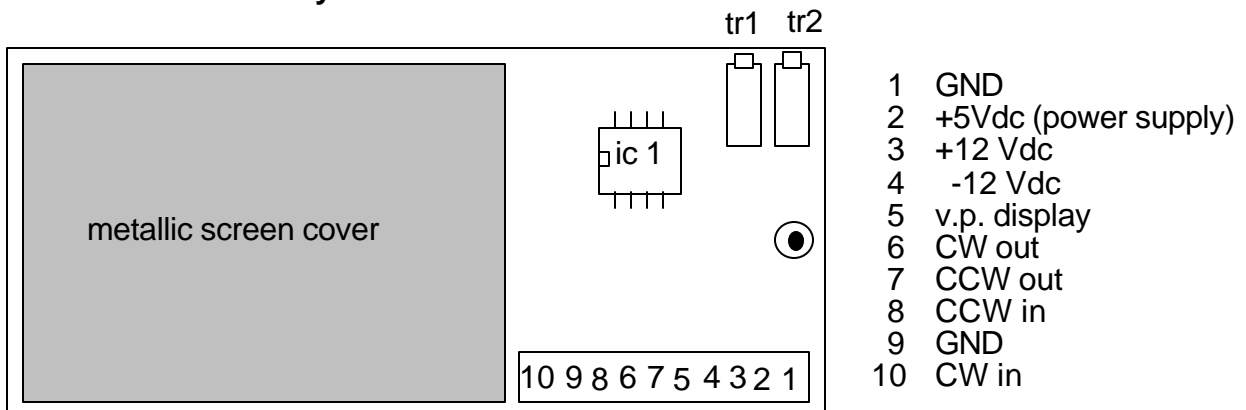

1.1 Display/Preset Circuit Board

The display/preset circuit board is mounted inside the control box in vertical position on the back of the control box front panel. A three digit, 7 segment display is driven by two microcontrollers with special software. The voltage on the wiper of the potentiometer (P) that is mounted in the motor assembly is applied to DC amplifier IC1 through terminal (v.p.). The proper voltage level is set by trimmer tr1. This calibrated voltage is fed to a digital to analog converter. The digital information is processed by one of the microcontrollers to generate the bearing readout.

You can monitor the voltage applied to the A/D (digital to analog converter) by shutting the control box off and depressing the paddle in the CW direction while turning the control box power back on. Three horizontal bars will start to flash on the display. Release the paddle and a relative voltage will be displayed (relative voltage mode). The chart below is a guide showing the display reading verses the bearing. Note that the decimal point/points are not in the correct position – this is a relative reading. The actual voltage applied to the A/D is 0.00 Vdc at 110° and 5.00 Vdc at 240°. The direction paddle can be used to turn the rotator in this mode and the display will indicate the relative A/D voltage. Remember, this is the voltage applied to the A/D and not the potentiometer voltage (P) that is fed from the motor assembly to the control box although these voltages are proportional. To get out of the relative voltage mode, turn the control box off.

Relative Voltage Mode

Display Readout vs. Bearing

Display	00.0.	07.0	16.0	25.0	34.0	43.0	5.0.0
Deg.	110	180	270	000	090	180	240
	CCW	S	W	N	E	S	CW
	Limit						Limit

1.2 Overlap

The display will also indicate whether or not you are in the overlap mode. If you are turning in the CW direction (east to south) and pass 180°, the left decimal point will light. If you are turning in the CCW direction (west to south) and pass 180°, the right decimal point will light.

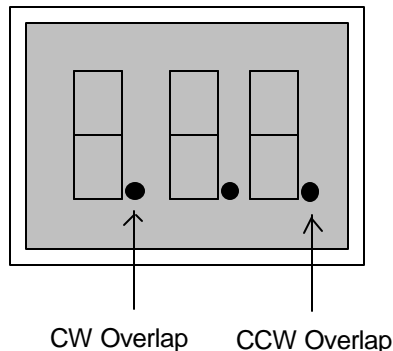

1.3 Preset Function

The preset control may be used to turn the rotator in lieu of the paddle. The preset knob can be rotated in either direction and has no stops. To preset a bearing, rotate the preset knob to the desired direction (the preset may be set within 3°). As you rotate the knob, the three decimal points on the display will start to flash and preset bearing will be displayed. After you have set the desired preset bearing, there will be a slight delay and the display will indicate the actual antenna bearing. The rotator will turn and the display will follow the antenna direction until it arrives at the preset bearing.

2 Pre-installation Check.

Before you connect the rotator control cable to control box, switch on the control box, and the display should indicate approximately 110°. Switch off the control box and connect the rotator control cable. The display should indicate approximately 110°. Rotate the preset knob to 000°. After a slight delay the rotator should turn in the CW direction and stop at 000°. Verify that the rotator is operating properly. Check both directions of rotation, both electronic limits and the preset function.

3 000° Calibration Procedure

If the initial antenna alignment is not correct, you can set it by adjusting trimmer TR4 located on the main board (see figure below). The correction range is about $\pm 15^\circ$. Follow the steps listed below.

- 1 - Remove the control box top cover.
- 2 - Turn trimmer TR4 (located on the main board) to maximum CCW.
- 3 - Switch on the control box in the "relative voltage mode" (see 1.1 above). Using the paddle, rotate the rotator until the display indicates a relative voltage of "00.0".
- 4 - Turn TR4 in CW direction until the display indicates a relative voltage of "01.5".
- 5 - Using the paddle, rotate the rotator so the display indicates a relative voltage of "00.0".
- 6 - Make reference marks on the rotator plate and rotator body. Using the paddle, rotate the rotator one full turn until the reference marks align. The display should indicate a relative voltage of "36.0". If it does not, slowly adjust trimmer TR1 (located on the display/preset board) until the display indicates "36.0".
- 7 - Using the paddle, rotate the rotator until the display indicates a relative voltage of "25.0". Turn the control box off and turn it back on. The display should indicate a bearing of 000°.

The control box is now calibrated and the rotator is ready for installation. If you experience a small error in the antenna bearing after installation, you can make up to a $\pm 10^\circ$ correction by adjusting trimmer TR4. It may be necessary to go through the above 000° alignment procedure if you have significant error with the antenna rotated 360°.

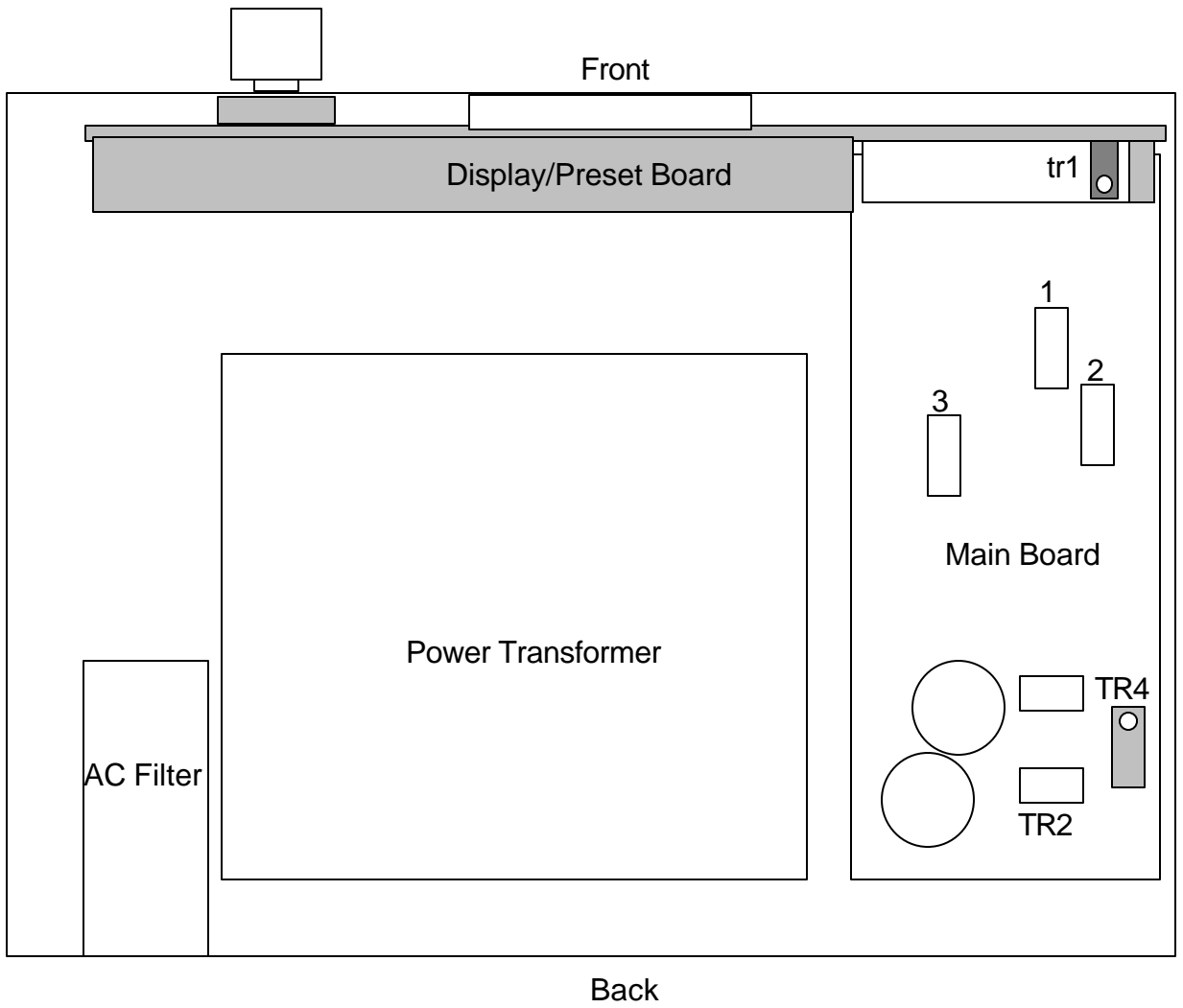

Model B Control Box (Top View)

Model "C" Control Box

Features:

- Voice synthesizer
- Keypad command entry
- 9 memories
- Selectable soft start and soft stop
- +70° and -70° rotation overlap (total rotation range of 500°)
- Manual command with reverse delay
- RS232 computer control compatible
- Selectable north or south stop

Warning: The control box is complex. Follow the instructions described below. Before mounting the rotator in the tower, thoroughly test the rotator on the ground and verify proper operation of the motor and control box functions.

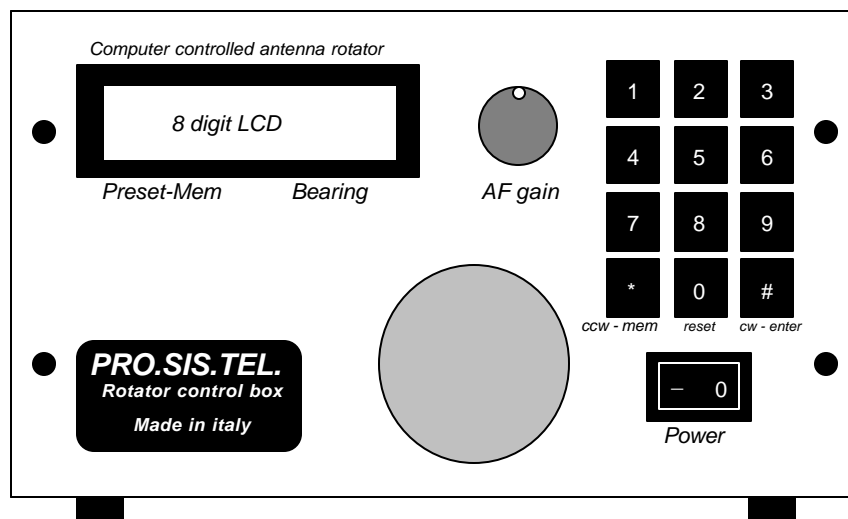

Control Box Front Panel

1. CPU/Indicator PC Board

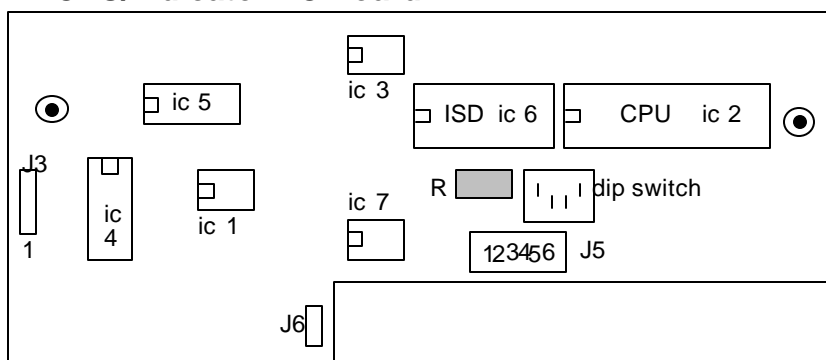

J5 connections

- 1 CW out
- 2 CCW out
- 3 U signal in
- 4 +12Vdc (Af power supply)
- 5 +5Vdc (power supply)
- 6 GND

J6 = loudspeaker

J3 connections (RS232)

- 1 Data in
- 2 Data out
- 4 GND

CPU Circuit Board

The CPU/Indicator circuit board is vertically mounted on the back of the front panel. The eight digit LCD display is driven by a microcontroller and displays the antenna bearing.

The voltage on the wiper of the potentiometer (U) that is mounted in the motor assembly is applied to a DC amplifier . The proper voltage level is set by trimmer TR2. This calibrated voltage is fed to a digital to analog converter. The digital information is processed by one of the microcontrollers to generate the bearing readout. Note that the “Vdc” values are relative.

South Stop

Vdc	000	070	160	250	340	430	500
Deg.	110	180	270	000	090	180	240
	East Limit	S	W	N	E	S	West Limit

North Stop

Vdc	000	070	160	250	340	430	500
Deg.	290	000	090	180	270	000	070
	West Limit	N	E	S	W	N	East Limit

When the dc voltage coming from the rotator motor potentiometer is 0 Vdc, the display will indicate 110° when configured for South Stop (default) and 290° when configured for a North Stop. If the rotator potentiometer wiper is at 2.5 Vdc, the display will indicate 000° when configured with a south stop and 180° when configured for a north stop.

If you desire to read the relative dc voltage, switch the control box off . Press and hold the CCW-MEM key while turning on the power. Release the key after the bearing is displayed. The left side of the display will indicate the potentiometer wiper voltage. Note that the display will indicate the relative dc voltage, i.e. when the actual voltage is 2.50 Vdc the display will indicate “250”. This function can be used to check for proper operation of the rotator potentiometer and initial antenna alignment. To return the control box back to normal operation, press the “0” key (reset).

2 – Pre-installation Check

Do not connect the control cable to the control box. Turn the control box on an the display will indicate “WARM UP” followed by music from the speaker. Verify that the display indicates a bearing of 110° for south stop or 290° for a north stop. Switch the control box off and connect the control cable. Turn the control box on and the display

should indicate approximately 110 or 290° depending on depending on the potentiometer position inside the motor unit. Press the “0” key (entering 00 or 000 give the same results) and then press “enter”. The rotator will start to turn in the clockwise (CW) direction and stop when the display indicates 000° . While the rotator is turning, an arrow will flash on the right side of the display.

3 - Electronic Bearing Alignment (000° set)

Discrepancy between the actual antenna bearing and the bearing displayed on the control box can be corrected. Corrections up to $\pm 15^\circ$ can be made using the following procedure.

- 1- Remove the top cover of the control box.
- 2- Turn trimmer TR4 in the CCW direction until it hit the end of its travel.
- 3- Turn the control box on in the “relative dc voltage” mode.
- 4- Turn the rotator until the left display reads “000”.
- 5- Turn trimmer TR4 clockwise (CW) until the display reads “015”.
- 6- Turn the rotator again so that the left display reads “000”.
- 7- Make reference marks on the rotator body and the mast mounting plate. Turn the rotator 1 full turn until the marks realign. The left display should read “360”. If it does not, adjust TR2 so that the left display reads “360”.

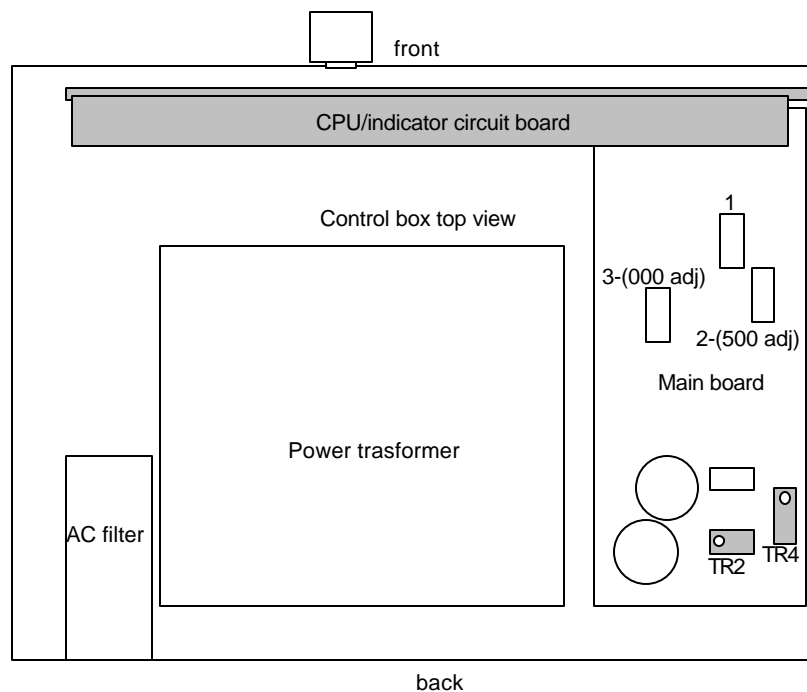

4 – Voice Synthesizer

All voice commands are preset and in memory. The synthesized voice repeats the command via the front panel speaker. The volume control is located on the front panel. This function is convenient for the visual impaired.

5 – Keypad Functions

Key pad allows you to enter the following commands:

Preset, call memory, write memory, reset memory, reset command, CW and CCW manual commands. If you press the same key number (1-9) 4 times or 4 different key numbers (1-9), the last key stroke will reset the command.

- Manual Bearing Entry:

The desired bearing may be manually entered. Enter the desired bearing by depressing the 3 keypad digits. A bearing between 000 and 359 may be selected. The display will show the wanted bearing. Press enter key. The rotator will start rotation in the direction of the shortest travel between the present position and the manually entered bearing.

- Entering a Bearing in Memory (Write/Rewrite memory)

Nine (9) bearings may be stored in memory. The locations are 1 through 9 (not 0). Turn the rotor on the desired bearing to be entered in to memory. Depress and hold the desired memory location key (1 through 9 – not 0) for 3 seconds. This bearing is now in memory. A memory position may be overwritten by repeating the above procedure.

- Recall Memory

Select and press the memory location number (1 through 9). Press the “mem” key. The display will show the position stored in the memory. Press enter to execute.

- Reset Memory

Turn the control box off. Press and hold the “0” key while switching the control box on, keeping the “0” key depressed for at least 3 seconds. Release the “0” key and the display will show “RESET ME”. Press enter to reset all 9 memories.

- Reset command

Any command that is being executed may be reset or stopped by depressing the “0” key.

-Manual CCW-CW Rotation

Manual rotation can be executed by depressing and holding the “*” key for CCW rotation, or the “#” key for CW rotation. The control box provides a 3 second reverse delay in the manual mode.

6 - Soft Start - Soft Stop

When executing a manually entered bearing or a bearing located in memory, a soft start /soft stop feature is provided. The duration of the soft start/stop time is selectable via the settings of DIP switch 2 and 3 located on the CPU board.

Switch

2 3

on - on = Soft functions disabled

off - on = Minimum soft start/stop time

on - off = Nominal soft start/stop time

off - off = Maximum soft start/stop time (default)

Minimum soft/start/stop time is provided when using the CW and CCW manual commands.

7 - South stop - North stop

South stop or north stop may be selected. DIP switch 1 located on the CPU board selects this function.

on = South stop (default)

off = North stop

8 - RS 232 Communication Protocol

RS232 allows you to control rotator from a computer via the DB9 connector located on the control box rear panel.

OUTPUT COMMANDS

Chr\$(2) = Clear buffer

Chr\$(48)&Chr(57) = Any number between 0 to 359

Chr\$(48) = Abort

Chr\$(13)(enter) = Go

Cannon DB9 connections:

pin 2 = serial data out

pin 3 = serial data in

pin 5 = computer GND

NOTES:

The program software used to control the rotator functions is stored in the CPU (IC 2) memory. If CPU IC is removed, the software will be lost and the control box will not function and must be reinitialized.

When the control box is not powered, CPU memory back-up voltage is supplied via a large capacitor located on the CPU board. To avoid the loss of the software, power should be applied to the control box at least every 6 months. This will recharge the back-up capacitor. Should the control box not function after an extended unpowered storage period, it must be reinitialized.

To initialize the control box:

Turn on the power

Press "555" and press the "cw enter" key

Press "819" and press the "cw enter" key

Connector Information

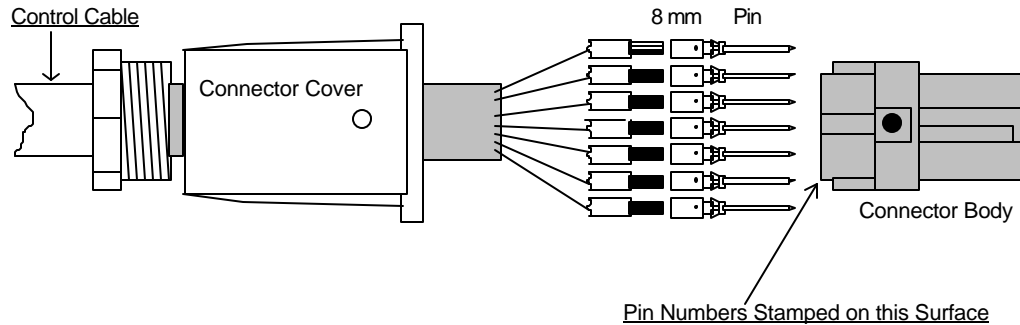

Connector Cover: Mencom/ILME P/N CK-03V
Connector Body: Mencom/ILME P/N CDM-07
Connector Pin: Mencom/ILME P/N CDMA 2.5

Connector parts are available in the USA through:

Mencom Corporation
1649 Oakbrook Dr.
Gainesville, GA 30507
Ph: 770-534-4585

Midwest distributor is:

Affiliated Control
640 Wheat Ln.
Wood Dale, IL 60191
Ph: 630-595-4680